





Revision	Date	Written by	Description			
<h1>CASH DISPENSING UNIT</h1> <h2>(Model : GBM, GBM1000)</h2> <h1>COMMUNICATION & COMMAND</h1> <h1>REFERENCE MANUAL</h1>						
MODEL: GBM,GBM1000	 <small>INFORMATION&COMMUNICATIONS CO., LTD.</small>		Written	K.S.KIM	05-07-19	Sheet
TITLE: COMMUNICATION & COMMAND REFERENCE MANUAL			Checked	H.B.LEE	05-07-19	1
			Rev.: 3.0	Approved	E.J.LEE	05-07-19



Revision	Date	Written by	Description			
Contents						
			1. INTRODUCTION ----- 3			
			2. ELECTRICAL INTERFACE ----- 5			
			(1) CONNECTOR ----- 6			
			(2) INTERFACE SELECTION ----- 7			
			(3) POWER CHANNEL SPECIFICATION ----- 8			
			3. SERIAL INTERFACE ----- 9			
			(1) DATA TRANSFER SPECIFICATIONS ----- 10			
			1) DATA CHARACTERISTICS ----- 10			
			2) DATA PROTOCOL DIAGRAMS ----- 10			
			3) SERIAL TRANSMISSION TIMMINGS ----- 12			
			4) CHARACTER FORMAT ----- 13			
			5) HANDSHAKE CONTROL ----- 14			
			(2) ELECTRICAL CONNECTION ----- 15			
			1) RS – 232C HANDSHAKE ----- 15			
			2) RS – 232C HANDSHAKE WITH EXIT COUNT BACK-UP ----- 15			
			(3) MESSAGE PROTOCOL ----- 17			
			1) STATUS COMMAND ----- 17			
			2) PURGE COMMAND ----- 19			
			3) DISPENSE COMMAND ----- 19			
			4) TEST DISPENSE COMMAND ----- 20			
			5) RESET COMMAND ----- 20			
			6) LAST STATUS COMMAND ----- 20			
			7) CONFIGURATION STATUS COMMAND ----- 21			
			8) DOUBLE DETECT DIAGNOSTICS COMMAND ----- 22			
			9) SENSOR DIAGNOSTICS COMMAND ----- 23			
			10) SINGLE NOTE DISPENSE COMMAND ----- 24			
			11) SINGLE NOTE EJECT COMMAND ----- 24			
			12) DIAGNOSIS COMMAND ----- 25			
			13) INVALID COMMAND ----- 26			
			4. ERROR CODES ----- 27			
MODEL: GBM,GBM1000			Written	K.S.KIM	05-07-19	Sheet
TITLE: COMMUNICATION & COMMAND REFERENCE MANUAL			Checked	H.B.LEE	05-07-19	2
			Approved	E.J.LEE	05-07-19	29



Revision	Date	Written by	Description			
<h1><u>1. INTRODUCTION</u></h1>						
MODEL: GBM,GBM1000	 TAEVAM INFORMATION&COMMUNICATIONS CO., LTD.		Written	K.S.KIM	05-07-19	Sheet
TITLE: COMMUNICATION & COMMAND REFERENCE MANUAL			Checked	H.B.LEE	05-07-19	3
			Rev.: 3.0	Approved	E.J.LEE	05-07-19



Revision	Date	Written by	Description			
<p>1.INTRODUCTION</p> <p>This document explains software protocol interface connection for Cash Dispensing Unit (Model name: GBM,GBM1000) and host. The GBM supports two types of interfaces through standard RS-232C 25 pin connector.</p> <ul style="list-style-type: none">● RS – 232C SERIAL (non-pollled, hand shake)● RS – 232C SERIAL (pollled) <p>Also, it explains the electrical interface about interface and power cable connections. This document is based on SDD emulation. For other information, please contact us.</p>						
MODEL: GBM,GBM1000			Written	K.S.KIM	05-07-19	Sheet
TITLE: COMMUNICATION & COMMAND REFERENCE MANUAL			Checked	H.B.LEE	05-07-19	4
			Rev.: 3.0	Approved	E.J.LEE	05-07-19



Revision	Date	Written by	Description			
<h2><u>2. ELECTRICAL INTERFACE</u></h2>						
MODEL: GBM,GBM1000	 TAEVAM INFORMATION&COMMUNICATIONS CO., LTD.		Written	K.S.KIM	05-07-19	Sheet
TITLE: COMMUNICATION & COMMAND REFERENCE MANUAL			Checked	H.B.LEE	05-07-19	5
			Rev.: 3.0	Approved	E.J.LEE	05-07-19



Revision	Date	Written by	Description
----------	------	------------	-------------

2.ELECTRICAL INTERFACE

(1) CONNECTOR

The interface connector is a standard male, 25 pin RS-232C 'D-type' connector. The opposite connector should be standard 25 pin RS-232C female connector.

The pin connections are as follows:

PIN	NAME	FUNCTION	DIRECTION	Remark
1				
2	TxD	Transmitted data	Out	
3	RxD	Received data	In	
4	RTS	Request to Send	Out	
5	CTS	Clear to Send	In	
6				
7	GND	System ground	Out	
8				
9				
10	ER	Enable reference, 0V	In	
11				
12				
13				
14				
15				
16				
17				
18				
19				
20				
21				
22	IS0	Interface select	In	
23	IS1	Interface select	In	
24				
25				

MODEL: GBM,GBM1000		Written	K.S.KIM	05-07-19	Sheet
TITLE: COMMUNICATION & COMMAND REFERENCE MANUAL		Checked	H.B.LEE	05-07-19	6
		Rev.: 3.0	Approved	E.J.LEE	05-07-19



Revision	Date	Written by	Description									
<p>(2) INTERFACE SELECTION</p>												
<p>Various interfaces options are available upon customer's request. An interface option is selected using links in the connector. An interface must be selected and enabled before it will operate.</p>												
<p>Selection links are specified in the following table:</p>												
<table border="1" data-bbox="248 546 1355 739"> <tr> <td data-bbox="248 546 509 593">RS-232C</td> <td data-bbox="509 546 1355 593">LINK CONNECTION</td> </tr> <tr> <td data-bbox="248 593 509 640">Non-pollled</td> <td data-bbox="509 593 1355 640">Pin 5(CTS) --- Handshake with Host</td> </tr> <tr> <td data-bbox="248 640 509 739" rowspan="2">Polled</td> <td data-bbox="509 640 1355 687">Pin 10(ER) --- Pin 22(IS0) or Pin 10(ER) --- Pin 22(IS0) --- Pin 23(IS1)</td> </tr> <tr> <td data-bbox="509 687 1355 739">Pin 4(RTS) --- Pin 5(CTS)</td> </tr> </table>						RS-232C	LINK CONNECTION	Non-pollled	Pin 5(CTS) --- Handshake with Host	Polled	Pin 10(ER) --- Pin 22(IS0) or Pin 10(ER) --- Pin 22(IS0) --- Pin 23(IS1)	Pin 4(RTS) --- Pin 5(CTS)
RS-232C	LINK CONNECTION											
Non-pollled	Pin 5(CTS) --- Handshake with Host											
Polled	Pin 10(ER) --- Pin 22(IS0) or Pin 10(ER) --- Pin 22(IS0) --- Pin 23(IS1)											
	Pin 4(RTS) --- Pin 5(CTS)											
<p>NOTE) After RESET or POWER-UP, the interface is selected instantly. And the selected interface is valid until next POWER-UP or RESET. Before POWER UP or RESET, the interface connector should be present.</p>												
MODEL: GBM,GBM1000				Written	K.S.KIM	05-07-19	Sheet					
TITLE: COMMUNICATION & COMMAND REFERENCE MANUAL				Checked	H.B.LEE	05-07-19	7					
				Rev.: 3.0	Approved	E.J.LEE	05-07-19	29				



Revision	Date	Written by	Description				
<p>(3) Power channel specification</p> <ul style="list-style-type: none"> ● Channels required <ul style="list-style-type: none"> 5Vdc ± 0.2V : Normal 700mA (Peak 1.6A) 36Vdc ± 2V : Normal 2A (Peak 4A) or 24Vdc ± 2V : Normal 2A (Peak 4A) <p>Use 0.156" pitch 7-way kk crimp terminal housing of Molex. The manufacturer's part number is 5239-07.</p> <ul style="list-style-type: none"> ● Pin description <ul style="list-style-type: none"> Pin 1: GND Pin 2: +5V Pin 3: F.G. (Frame ground) Pin 4: +5V Pin 5: N.C. (No connection) Pin 6: GND Pin 7: +36V DC (or +24V DC) <p>GND of pin 1 and pin 6 are shorted</p> <p>The GBM body must be earthed. To accomplish this, make GBM body connected to earth thru system case (preferred), or use F.G. connection.</p> <ul style="list-style-type: none"> ● Recommended – power rating. <ul style="list-style-type: none"> (Power supply, of that power rating is 150 W or more, is recommended.) 							
MODEL: GBM,GBM1000				Written	K.S.KIM	05-07-19	Sheet
TITLE: COMMUNICATION & COMMAND REFERENCE MANUAL				Checked	H.B.LEE	05-07-19	8
				Rev.: 3.0	Approved	E.J.LEE	05-07-19



Revision	Date	Written by	Description			
<h1><u>3. SERIAL INTERFACE</u></h1>						
MODEL: GBM,GBM1000	 TAEVAM INFORMATION&COMMUNICATIONS CO., LTD.		Written	K.S.KIM	05-07-19	Sheet
TITLE: COMMUNICATION & COMMAND REFERENCE MANUAL			Checked	H.B.LEE	05-07-19	9
			Rev.: 3.0	Approved	E.J.LEE	05-07-19



Revision	Date	Written by	Description		
----------	------	------------	-------------	--	--

3. SERIAL INTERFACE

(1) DATA TRANSFER SPECIFICATIONS

1) DATA CHARACTERISTICS

- Transmission rate: 4800 bps
- Parity: Even
- Character length: 7 bits + parity
- Number of stop bits: 1
- Message BCC: LRC

2) DATA PROTOCOL DIAGRAMS

2-1) SERIAL INTERFACE WITH NO HANDSHAKE

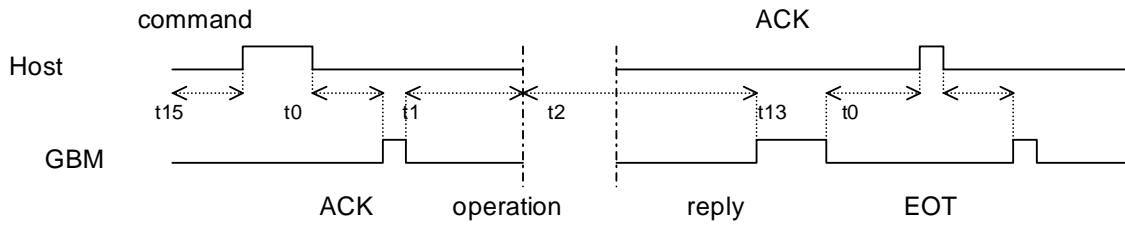

2-2) SERIAL INTERFACE WITH HANDSHAKE

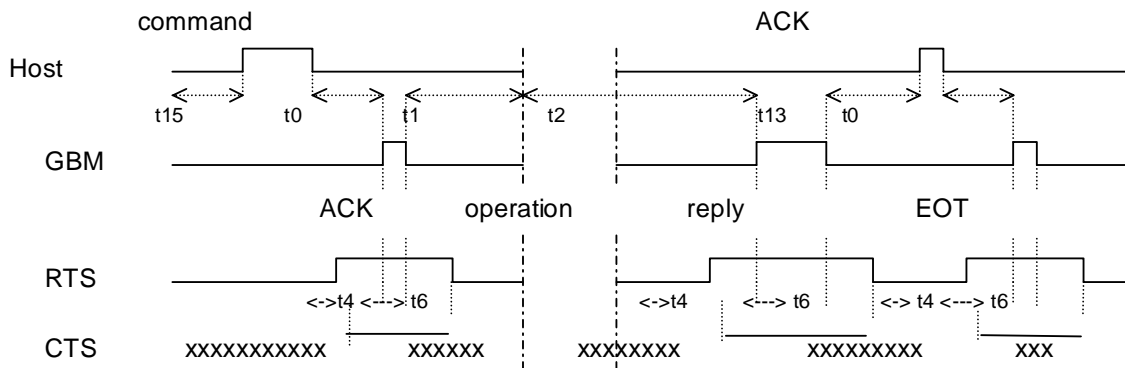

MODEL: GBM,GBM1000		Written	K.S.KIM	05-07-19	Sheet
TITLE: COMMUNICATION & COMMAND REFERENCE MANUAL		Checked	H.B.LEE	05-07-19	10
		Rev.: 3.0	Approved	E.J.LEE	05-07-19



Revision	Date	Written by	Description
----------	------	------------	-------------

2 – 3) SERIAL INTERFACE WITH POLLING OPTION

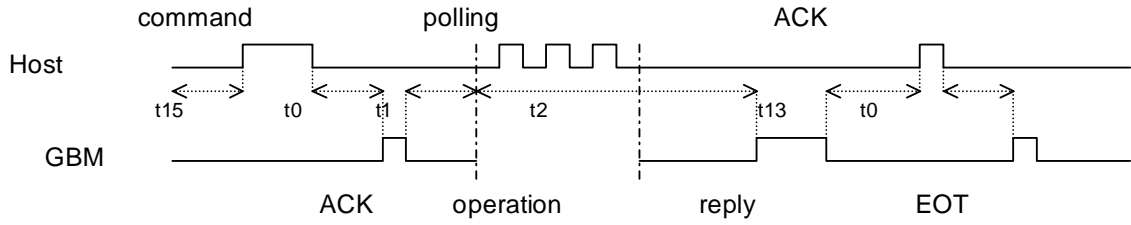

2 – 4) SERIAL INTERFACE WITH EIXT COUNT BACK-UP

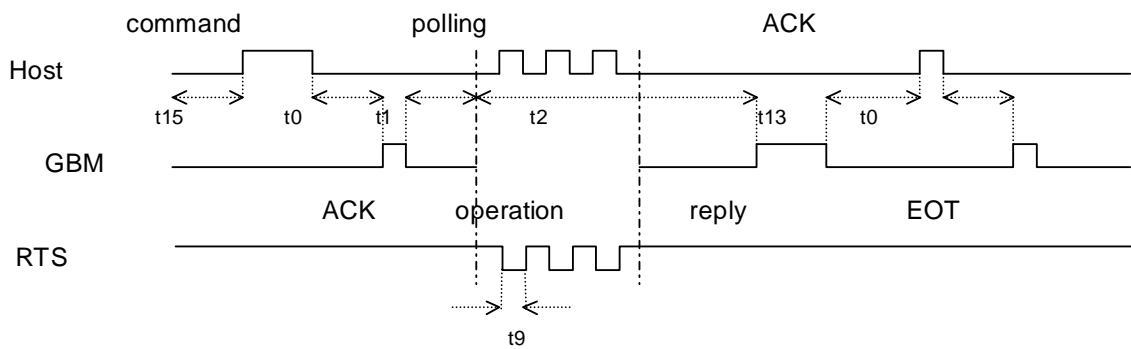

MODEL: GBM,GBM1000		Written	K.S.KIM	05-07-19	Sheet
TITLE: COMMUNICATION & COMMAND REFERENCE MANUAL		Checked	H.B.LEE	05-07-19	11
		Rev.: 3.0	Approved	E.J.LEE	05-07-19



Revision	Date	Written by	Description
----------	------	------------	-------------

3) SERIAL TRANSMISSION TIMINGS

3-1) GBM TIMINGS

Sign	Min(ms)	Max(ms)	Explanation
t0	50	100	Delay to transmit ACK, NAK, EOT(CTS on)
t1	500		Delay for starting of operation after ACK
t2	100		Delay to transmit after it begins operation (CTS on)
t3	500	550	Timeout delay to receive ACK
t4	0	50	Delay to transmit after CTS on
t5	50	100	Delay to transmit after poll
t6		100	Delay to put RTS inactively
t7	0	2	Spacing in characters
t8	50	100	Count pulse on RTS
t9	50	100	Exit count pulse on RTS

3-2) HOST TIMINGS

Sign	Min(ms)	Max(ms)	Explanation
t10	0	500	Spacing in characters
t11	550		Time for decision if a received message is ignored by the GBM
t12	100	300	Delay to repeat a command after it has received NAK
t13	100	500	Delay to send ACK, NAK
t14	150		Delay to send continual poll
t15	100		Delay to send a command after it has sent EOT

Note) GBM cannot receive a data if RTS is on. Therefore RTS can control the host's minimum transmission timing.

MODEL: GBM,GBM1000	 TAEVAM INFORMATION&COMMUNICATIONS CO., LTD.	Written	K.S.KIM	05-07-19	Sheet
TITLE: COMMUNICATION & COMMAND REFERENCE MANUAL		Checked	H.B.LEE	05-07-19	12
		Rev.: 3.0	Approved	E.J.LEE	05-07-19



Revision	Date	Written by	Description			
<p>4) CHARACTER FORMAT</p> <p>The protocol is half duplex and is inactive when a Purge or Dispense operation is in progress. The characters are a combination of ASCII, for headers, and binary, for data.</p> <p>All commands from the host and response from the GBM are on a one at a time basis. It means the GBM must reply to a message before another command will be received, and GBM cannot send an unexpected response. Messages are accepted by the transmission of an ACK and rejected by the transmission of a NAK. A NAK requests the message to be repeated. The GBM can be configured either to respond under the control of interface handshake circuits (CTS and RTS) or to respond only when polled by the host.</p> <p>When either the host or the GBM does not accept the message, it transmits NAK (ASCII, 15 hex) in place of ACK. Then, the message is resend until host or GBM accepts the message by sending an ACK. This can be repeated until ACK is received.</p> <p>When the host does not accept the message, it decides when to stop trying for repeating and to terminate it by sending an ACK or EOT. Except an EOT, any character in place of ACK is treated as a NAK.</p> <p>Characters with incorrect parity are treated as NUL character (ASCII, 0 hex). This has the effect of forcing a NAK to a message or of treating an ACK character with parity error as an NAK.</p> <p>All messages are followed by a BCC (Block Check Character), which is generated by an LRC (Longitudinal Redundancy Check) of the entire message. If the BCC character is valid, the message is accepted with an ACK. If not so, that message is ignored by a NAK.</p> <p>If the GBM sends an ACK to the host after received a command, it will not action any command for 500ms. When received new command for this period, the GBM adopts the new command in place of previous command. This procedure protects the communications interface confusion.</p>						
MODEL: GBM,GBM1000			Written	K.S.KIM	05-07-19	Sheet
TITLE: COMMUNICATION & COMMAND REFERENCE MANUAL			Checked	H.B.LEE	05-07-19	13
			Rev.: 3.0	Approved	E.J.LEE	05-07-19



Revision	Date	Written by	Description			
<p>- Character usage</p> <p>EOT (hex 04): used in host's start and GBM's termination in the communication.</p> <p>BCC: used for checking whether a message is valid or invalid with the LRC.</p> <p style="padding-left: 40px;">The LRC is XOR for all character in the message.</p> <p>ID (30 hex ~ 33 hex): communications identity</p> <p>STX (02 hex): start of text</p> <p>SOH (01 hex): start of header</p> <p>ETX (03 hex): end of text</p> <p>ENQ(05 hex); enquiry</p> <p>5) HANDSHAKE CONTROL</p> <p>The GBM may be operated under control of the standard handshake or polling from the host.</p> <p>When the GBM is ready to transmit, it turns on the circuit RTS (Ready to Send). Also the GBM will not transmit until the circuit CTS (Clear to Send) is active. This prevents transmitting from the host until the GBM is ready to receive a message. Similarly the host also can prevent the message transmitted from the GBM with the circuit CTS off.</p> <p>When it is not handshake mode, the circuit CTS and RTS should be connected together. But if the polled interface is opted, the GBM will not reply to a message until it receives the poll string.</p> <p>In the poll mode, GBM has three option</p> <ul style="list-style-type: none"> o,1 Send the response to a previous command. o,2 Send an EOT when no response pending o,3 Ignore the poll in operation of previous command. <p>The poll is composed of following three characters.</p> <p>EOT – start of transmission(04 hex)</p> <p>ID – communication identity(30 ~ 33 hex)</p> <p>ENQ – enquiry (05 hex)</p>						
MODEL: GBM,GBM1000			Written	K.S.KIM	05-07-19	Sheet
TITLE: COMMUNICATION & COMMAND REFERENCE MANUAL			Checked	H.B.LEE	05-07-19	14
			Rev.: 3.0	Approved	E.J.LEE	05-07-19



Revision	Date	Written by	Description			
<p>(2) ELECTRICAL CONNECTIONS</p> <p>1) RS – 232C INTERFACE</p> <p>This interface is applied to the EIA RS – 232C standard.</p> <p>The connector configuration is as follows:</p> <p>Pin1 SCRN – Cable screen (If required).</p> <p style="padding-left: 40px;">The cable screen is used when the interface is finished.</p> <p>Pin2 TxD – Transmitted data</p> <p>Pin3 RxD – Received data</p> <p>Pin4 RTS – Request to send. If the GBM want to send some data, then the RTS is become active (on, –12V)</p> <p>Pin5 CTS – Clear to send. Only if the RTS made by the host is active, the GBM transmits a data. The CTS is become active when the RTS is on state.</p> <p>Pin7 GND – Communication ground</p> <p>The pin 4 (CTS) and pin 5 (RTS) should be connected with each other in case of no handshake. On the other hand, the polled interface is selected by linking the pin 22 and the pin 10. To select this way, the CTS is linked to RTS and the communication identity should be selected by using pin 12, 24 and 25.</p> <p>2) RS – 232C INTERFACE WITH EXIT COUNT BACK-UP</p> <p>This interface is designed to the EIA RS-232C standard. The GBM is configured as DTE but uses none of the handshake circuits. It is configured as a polled interface.</p> <p>The RTS circuit (pin 4) is pulsed by the GBM to indicate the appropriate number of notes past the exit sensor. The host can then count the pulses on RTS for use as a back-up in the event of power failure during a dispense.</p> <p>The connector configuration for this interface is as follows:</p> <p>Pin1 SCRN – Cable screen (If required).</p> <p style="padding-left: 40px;">The cable screen is used when the interface is finished.</p> <p>Pin2 TxD – Transmitted data</p> <p>Pin3 RxD – Received data</p> <p>Pin4 RTS – Request to send. If the GBM want to send some data, then the RTS is become active (on, –12V)</p> <p>Pin5 CTS – Clear to send. Only if the RTS made by the host is active, the GBM transmits a data. The</p>						
MODEL: GBM,GBM1000			Written	K.S.KIM	05-07-19	Sheet
TITLE: COMMUNICATION & COMMAND REFERENCE MANUAL			Checked	H.B.LEE	05-07-19	15
			Rev.: 3.0	Approved	E.J.LEE	05-07-19



Revision	Date	Written by	Description
			CTS is become active when the RTS is on state. Pin7 GND – Communication ground Pin10 ER } Pin22 IS0 } Pin10, 22, and 23 linked together Pin23 IS1 }

(3) MESSAGE PROTOCOL (SERIAL INTERFACE)

MODEL: GBM,GBM1000		Written	K.S.KIM	05-07-19	Sheet
TITLE: COMMUNICATION & COMMAND REFERENCE MANUAL		Checked	H.B.LEE	05-07-19	16
		Rev.: 3.0	Approved	E.J.LEE	05-07-19



Revision	Date	Written by	Description				
<p>The host can send the following twelve commands to the GBM.</p> <p>STATUS PURGE DISPENSE TEST DISPENSE RESET LAST STATUS CONFIGURATION STATUS DOUBLE DETECT DIAGNOSTICS SENSOR DIAGNOSTICS SINGLE NOTE DISPENSE SINGLE NOTE EJECT DIAGNOSIS</p> <p>1) STATUS COMMAND</p> <p>The Status command instructs the GBM to return the GBM's sensor and status. The status command and reply message are as follows:</p> <p>-Command message EOT, ID, STX, 40 hex, ETX, BCC</p> <p>The 40 hex is Status command character.</p> <p>-Reply message SOH, ID, STX, 40 hex, DATA0, DATA1, DATA2, DATA3, ETX, BCC</p> <p>DATA0 bit Explanation when a bit is '1' state</p> <p>0 Feed sensor blocked 1 Exit sensor blocked 2 Cassette low 3 Reset since last status message 4 Timing wheel sensor blocked</p>							
MODEL: GBM,GBM1000				Written	K.S.KIM	05-07-19	Sheet
TITLE: COMMUNICATION & COMMAND REFERENCE MANUAL				Checked	H.B.LEE	05-07-19	17
				Rev.: 3.0	Approved	E.J.LEE	05-07-19



Revision	Date	Written by	Description
	5		Abnormal double detect condition in last dispense
	6		Always 1
DATA1	bit	Explanation when a bit is '1' state	
	0	Always 0	
	1	Always 0	
	2	Always 0	
	3	Always 0	
	4	Double note detect	
	5	Sensor dirty (feed or exit)	
DATA2: The average thickness of delivered notes			
This is the calibration value of the double detect sensor.			
DATA2 = thickness + 20 hex			
DATA3: The average length of delivered notes			
This is the calibration value of the double detect sensor, and measured in units of 3.5 mm.			
DATA3 = length + 20 hex			
2) PURGE COMMAND			

MODEL: GBM,GBM1000		Written	K.S.KIM	05-07-19	Sheet
TITLE: COMMUNICATION & COMMAND REFERENCE MANUAL		Checked	H.B.LEE	05-07-19	18
		Rev.: 3.0	Approved	E.J.LEE	05-07-19



Revision	Date	Written by	Description			
<p>The Purge command instructs the GBM to remove all notes on delivering belts of the dispensing mechanism. Removed notes are sent to the reject bin of the GBM.</p> <p>The Purge command and the reply message are as follows;</p> <p>- Command message EOT, ID, STX, 41 hex, ETX, BCC</p> <p>The 41 hex is Purge command character.</p> <p>-Reply message SOH, ID, STX, 41 hex, ERROR, EXIT, REJECT, ETX, BCC</p> <p>The ERROR of the above characters is a character for indicating the error status during GBM operation; refer to section '(4) ERROR CODES' for all sorts of error code.</p> <p>The EXIT is a character for indicating the number of notes past the exit, and the REJECT is a character for indicating the number of the reject event. Each of them is calculated by same way as follows;</p> <p>EXIT = count + 20 hex REJECT = count + 20 hex</p> <p>3) DISPENSE COMMAND</p> <p>This command instructs the GBM to dispense notes in the cassette past the exit of the dispensing mechanism. In process of delivery, abnormal notes are saved to the reject bin and extra notes are dispensed to replace them. The command and reply message are as follows:</p> <p>-Command message EOT, ID, STX, 42 hex, QUANTITY, ETX, BCC</p> <p>In the above characters, the 42 hex is Dispense command character and the QUANTITY is the number of notes to be dispensed. (value = amount + 20hex)</p> <p>-Reply message</p>						
MODEL: GBM,GBM1000			Written	K.S.KIM	05-07-19	Sheet
TITLE: COMMUNICATION & COMMAND REFERENCE MANUAL			Checked	H.B.LEE	05-07-19	19
			Rev.: 3.0	Approved	E.J.LEE	05-07-19



Revision	Date	Written by	Description
			<p>SOH, ID, STX, 42 hex, ERROR, EXIT, REJECT, ETX, BCC</p> <p>The meaning of ERROR, EXIT and REJECT is equal to those of the Purge..</p> <p>4) TEST DISPENSE COMMAND</p> <p>This command instructs the GBM to save requiring notes into the reject bin. This is used for proving GBM's correct performance. The command and replay message format are equal to those of the Dispense. (Except that the 42 hex is replaced with 43 hex)</p> <p>5) RESET COMMAND</p> <p>This command instructs the GBM to enter its power-up condition. The GBM acknowledges the reception of the command, but doesn't send a response message. The Status command will indicate whether the reset was successful or not. Note, the reset is a full hardware reset of the GBM. The command is as follows:</p> <p>-Command message EOT, ID, STX, 44 hex, ETX, BCC</p> <p>The 44 hex is a Reset command character.</p> <p>6) LAST STATUS COMMAND</p> <p>This command instructs the GBM to return the status of last finished operation, such as last Purge, Dispense or Test dispense. The command and reply message are as follows:</p> <p>- Command message</p>

MODEL: GBM,GBMI000		Written	K.S.KIM	05-07-19	Sheet
TITLE: COMMUNICATION & COMMAND REFERENCE MANUAL		Checked	H.B.LEE	05-07-19	20
		Rev.: 3.0	Approved	E.J.LEE	05-07-19



Revision	Date	Written by	Description														
<p>EOT, ID, STX, 45 hex, ETX, BCC</p> <p>The 45 hex is the Last Status command character.</p> <p>-Reply message Equal to the Purge reply format. (Except that the 41 hex is replaced with 45 hex.)</p>																	
<p>7) CONFIGURATION STATUS COMMAND</p> <p>The Configuration Status command instructs the dispenser to send its firmware and mechanical configuration.</p> <p>- Command message EOT, ID, STX, 46 hex, ETX, BCC</p> <p>- Replay message SOH, ID, STX, 46 hex, DATA0, DATA1, DATA2, DATA3, ETX, BCC</p> <p>DATA0 Set to firmware version number DATA0 = VERSION + 20 hex</p> <p>DATA1 Set to firmware issue number DATA1 = ISSUE + 20 hex</p> <p>DATA2 bit Explanation when a bit is '1' state</p> <table border="0" data-bbox="343 1534 877 1848"> <tr><td>0</td><td>Transport type (see below)</td></tr> <tr><td>1</td><td>Currency type (1=French, 0 =Standard)</td></tr> <tr><td>2</td><td>Transport type (see below)</td></tr> <tr><td>3</td><td>Transport type (see below)</td></tr> <tr><td>4</td><td>Always 0</td></tr> <tr><td>5</td><td>Always 0</td></tr> </table>						0	Transport type (see below)	1	Currency type (1=French, 0 =Standard)	2	Transport type (see below)	3	Transport type (see below)	4	Always 0	5	Always 0
0	Transport type (see below)																
1	Currency type (1=French, 0 =Standard)																
2	Transport type (see below)																
3	Transport type (see below)																
4	Always 0																
5	Always 0																
MODEL: GBM,GBM1000				Written	K.S.KIM	05-07-19	Sheet										
TITLE: COMMUNICATION & COMMAND REFERENCE MANUAL				Checked	H.B.LEE	05-07-19	21										
				Rev.: 3.0	Approved	E.J.LEE	05-07-19	29									



Revision	Date	Written by	Description																																																											
<p>6 Always 1</p> <p>bit 0, 2, and 3 represent the transport type:</p> <table border="0"> <tr> <td>Bits</td> <td>3</td> <td>2</td> <td>0</td> <td></td> </tr> <tr> <td></td> <td>0</td> <td>0</td> <td>0</td> <td>Short length</td> </tr> <tr> <td></td> <td>0</td> <td>0</td> <td>1</td> <td>Standard length</td> </tr> <tr> <td></td> <td>0</td> <td>1</td> <td>0</td> <td>Rear delivery and Exit extension</td> </tr> <tr> <td></td> <td>0</td> <td>1</td> <td>1</td> <td>Rear Delivery</td> </tr> </table> <p>DATA3 bit Explanation when a bit is '1' state</p> <table border="0"> <tr> <td>0</td> <td>Always 0</td> </tr> <tr> <td>1</td> <td>Always 0</td> </tr> <tr> <td>2</td> <td>Protocol mode (see below)</td> </tr> <tr> <td>3</td> <td>Protocol mode (see below)</td> </tr> <tr> <td>4</td> <td>Always 0</td> </tr> <tr> <td>5</td> <td>Always 0</td> </tr> <tr> <td>6</td> <td>Always 1</td> </tr> </table> <table border="0"> <tr> <td>Bits</td> <td>3</td> <td>2</td> <td></td> </tr> <tr> <td></td> <td>0</td> <td>0</td> <td>Non-polled</td> </tr> <tr> <td></td> <td>0</td> <td>1</td> <td>Polled interface</td> </tr> <tr> <td></td> <td>1</td> <td>0</td> <td>Invalid Selection</td> </tr> <tr> <td></td> <td>1</td> <td>1</td> <td>Exit count backup</td> </tr> </table>				Bits	3	2	0			0	0	0	Short length		0	0	1	Standard length		0	1	0	Rear delivery and Exit extension		0	1	1	Rear Delivery	0	Always 0	1	Always 0	2	Protocol mode (see below)	3	Protocol mode (see below)	4	Always 0	5	Always 0	6	Always 1	Bits	3	2			0	0	Non-polled		0	1	Polled interface		1	0	Invalid Selection		1	1	Exit count backup
Bits	3	2	0																																																											
	0	0	0	Short length																																																										
	0	0	1	Standard length																																																										
	0	1	0	Rear delivery and Exit extension																																																										
	0	1	1	Rear Delivery																																																										
0	Always 0																																																													
1	Always 0																																																													
2	Protocol mode (see below)																																																													
3	Protocol mode (see below)																																																													
4	Always 0																																																													
5	Always 0																																																													
6	Always 1																																																													
Bits	3	2																																																												
	0	0	Non-polled																																																											
	0	1	Polled interface																																																											
	1	0	Invalid Selection																																																											
	1	1	Exit count backup																																																											
<p>8) DOUBLE DETECT DIAGNOSTICS COMMAND</p> <p>The double detect diagnostics command instructs the dispenser to operate its transport and feed system and report the amount of noise present on double detect system.</p> <p>Note, there should be no notes present during this test. If either the feed or exit sensor becomes blocked the operation will be aborted, preventing notes from being dispensed.</p> <p>This command is only required for diagnostics purpose.</p>																																																														
MODEL: GBM,GBM1000			Written	K.S.KIM	05-07-19	Sheet																																																								
TITLE: COMMUNICATION & COMMAND REFERENCE MANUAL			Checked	H.B.LEE	05-07-19	22																																																								
			Approved	E.J.LEE	05-07-19	29																																																								
		Rev.: 3.0																																																												



Revision	Date	Written by	Description
			<p>- Command message EOT, ID, STX, 47 hex, ETX, BCC</p> <p>- Replay message SOH, ID, STX, 47 hex, ERROR, DATA0, DATA1, DATA2, ETX, BCC</p> <p>ERROR: See 4. ERROR CODES page 22</p> <p>DATA0: Maximum value of unprocessed double detect sensor DATA0 = value + 20 hex</p> <p>DATA1: Maximum value of processed double detect sensor DATA1 = value + 20 hex</p> <p>DATA2: Average value of processed double detect sensor DATA2 = value + 20 hex</p> <p>9) SENSOR DIAGNOSTICS COMMAND</p> <p>The sensor diagnostics command returns data concerning direct measurements of document thickness and length and of diverter timing.</p> <p>Notes should be present for this command. The dispenser will run the transport in the forward direction for a short period to ensure the system has stabilized and then it will feed and reject one note. The reply message consists of measurements taken on this note. No notes are dispensed from the exit.</p> <p>The command is only required for diagnostics purposes.</p> <p>- Command message EOT, ID, STX, 48 hex, ETX, BCC</p> <p>- Replay message</p>

MODEL: GBM,GBM1000		Written	K.S.KIM	05-07-19	Sheet
TITLE: COMMUNICATION & COMMAND REFERENCE MANUAL		Checked	H.B.LEE	05-07-19	23
		Rev.: 3.0	Approved	E.J.LEE	05-07-19



Revision	Date	Written by	Description
<p>SOH, ID, STX, 48 hex, ERROR, DATA0, DATA1, DATA2, ETX, BCC</p> <p>ERROR: See 4. ERROR CODES page 22</p> <p>DATA0: The double level count of the note fed DATA0 = value + 20 hex</p> <p>DATA1: The length of the note fed in units of 3.5 mm. DATA1 = value + 20 hex</p> <p>DATA2: Diverter check time set (unit 1.4 ms) DATA2 = value + 50 hex</p> <p>10) SINGLE NOTE DISPENSE COMMAND</p> <p>The Single Note Dispense command instructs the dispenser to pick one note and stop with the note protruding from the exit. Notes will have a protrusion of approximately 30mm. The Purge command may be used to retract the note.</p> <p>- Command message EOT, ID, STX, 4Ahex, ETX, BCC</p> <p>The reply message is identical to that of standard dispense command with the exception that the Dispense command character (42 hex) is replaced with the Single Note Dispense command character (4A hex)</p> <p>11) SINGLE NOTE EJECT COMMAND</p> <p>This command may be used after a Single Note Dispense to instruct the GBM to drive the note held at the exit fully out of the exit. This command differs from the purge command which retracts and rejects the note.</p> <p>If there is no note at the exit, a standard purge will be performed. The command and response formats are identical to that for the purge command with exception that the command character is replaced with the Single Note Eject character (4B hex).</p> <p>12) DIAGNOSIS COMMAND</p>			

MODEL: GBM,GBM1000		Written	K.S.KIM	05-07-19	Sheet
TITLE: COMMUNICATION & COMMAND REFERENCE MANUAL		Checked	H.B.LEE	05-07-19	24
		Rev.: 3.0	Approved	E.J.LEE	05-07-19



Revision	Date	Written by	Description			
<p>This command instructs the GBM to return an error code and a reject status of a note has delivered just now with sensors. So this is generally used for investigating if a delivered note is normal or not. In this operation, the note is gone into the reject bin. The command and replay message are as follows:</p> <p>- Command message EOT, ID, STX, 52 hex, ETX, BCC</p> <p>The 52 hex is the Diagnosis command character.</p> <p>- Replay message SOH, ID, STX, 52 hex, ERROR, EXIT, REJECT, DATA0, DATA1 ETX, BCC</p> <p>The meaning of ERROR, EXIT and REJECT is equal to those of the Purge. And both DATA0 and DATA1 indicate the information of rejected notes during the last operation.</p> <p>DATA0 bit Explanation when a bit is '1' state</p> <ul style="list-style-type: none"> 0 Detect a long note 1 Detect a short note 2 Detect the note made a hole at S15 sensor 3 Detect the note made a hole at S16 sensor 4 Always 0 5 Always 1 <p>DATA1 bit Explanation when a bit is '1' state</p> <ul style="list-style-type: none"> 0 Detect an abnormal space among notes. (Comparing with already fixed space) 1 Detect a half note at S15 sensor 2 Detect a half note at S16 sensor 3 Detect a double note at detect sensor 4 Always 0 5 Always 1 <p>13) INVALID COMMAND</p>						
MODEL: GBM,GBM1000			Written	K.S.KIM	05-07-19	Sheet
TITLE: COMMUNICATION & COMMAND REFERENCE MANUAL			Checked	H.B.LEE	05-07-19	25
			Rev.: 3.0	Approved	E.J.LEE	05-07-19



Revision	Date	Written by	Description			
<p>If the GBM receives a invalid command from the host except above mentioned commands, it will reply to the host as follows:</p> <p>- Reply message SOH, ID, STX, 4F hex, ETX, BCC</p> <p>The 4F hex is a invalid command character.</p>						
MODEL: GBM,GBM1000			Written	K.S.KIM	05-07-19	Sheet
TITLE: COMMUNICATION & COMMAND REFERENCE MANUAL			Checked	H.B.LEE	05-07-19	26
			Approved	E.J.LEE	05-07-19	29



Revision	Date	Written by	Description			
<h1><u>4. ERROR CODES</u></h1>						
4. ERROR CODES						
MODEL: GBM,GBM1000	 TAEVAM INFORMATION&COMMUNICATIONS CO., LTD.		Written	K.S.KIM	05-07-19	Sheet
TITLE: COMMUNICATION & COMMAND REFERENCE MANUAL			Checked	H.B.LEE	05-07-19	27
			Rev.: 3.0	Approved	E.J.LEE	05-07-19



Revision	Date	Written by	Description																																																																																												
<p>The rest except 20 hex (good operation) are returned if only an abnormal event occurs during operation. For proper operation, there should not be notes on the delivering belts. If not, the GBM will automatically remove such notes into the reject bin before its operation. (Excepting for the errors with '*'). Most of errors are self-recoverable, but if it occurs a failed operation, the reported error is the final error to cease operation. A real error is that the exit count does not match the requested amount.</p>																																																																																															
<table border="1"> <thead> <tr> <th>CODE(hex)</th> <th>ERROR</th> <th colspan="4">The cause of errors, or explanation</th> </tr> </thead> <tbody> <tr> <td>20</td> <td>Good operation</td> <td colspan="4"></td> </tr> <tr> <td>21</td> <td>Feed failure</td> <td colspan="4">Failure to pick notes from the cassette</td> </tr> <tr> <td>22</td> <td>Mistracked note at feed</td> <td colspan="4">Note arrived at feed sensor while note still is at double detect</td> </tr> <tr> <td>23</td> <td>Mistracked note at double detect</td> <td colspan="4">Without being seen at feed sensor, note arrived at double detect</td> </tr> <tr> <td>24</td> <td>Mistracked note at exit</td> <td colspan="4">Without being seen at exit sensor, note arrived at other sensor</td> </tr> <tr> <td>25*</td> <td>Note too long at exit</td> <td colspan="4">Current note is longer than allowed note at the exit sensor</td> </tr> <tr> <td>26*</td> <td>Blocked exit</td> <td colspan="4">When the exit sensor is covered at start of dispense, the GBM will accept only the Purge command.</td> </tr> <tr> <td>27</td> <td>Too many notes</td> <td colspan="4">The notes detected by the exit sensor are more than the required notes</td> </tr> <tr> <td>2A*</td> <td>Timing wheel</td> <td colspan="4">When the delivery belts of the GBM does not operate.</td> </tr> <tr> <td>2C</td> <td>Bad roller profile</td> <td colspan="4">In case of that a noise occurs at the double detect sensor</td> </tr> <tr> <td>2D*</td> <td>Reject error</td> <td colspan="4">When the GBM has failed to reject an abnormal note</td> </tr> <tr> <td>2E</td> <td>Exit quantified</td> <td colspan="4">When the count at the exit disagrees with other sensors</td> </tr> <tr> <td>2F</td> <td>Note missing at double detect</td> <td colspan="4">When an note detected by the feed sensor isn't seen at the double detect</td> </tr> <tr> <td>30</td> <td>Reject rate Exceed</td> <td colspan="4">When reject events are more than 5, If more than 8, operation will be stopped.</td> </tr> </tbody> </table>						CODE(hex)	ERROR	The cause of errors, or explanation				20	Good operation					21	Feed failure	Failure to pick notes from the cassette				22	Mistracked note at feed	Note arrived at feed sensor while note still is at double detect				23	Mistracked note at double detect	Without being seen at feed sensor, note arrived at double detect				24	Mistracked note at exit	Without being seen at exit sensor, note arrived at other sensor				25*	Note too long at exit	Current note is longer than allowed note at the exit sensor				26*	Blocked exit	When the exit sensor is covered at start of dispense, the GBM will accept only the Purge command.				27	Too many notes	The notes detected by the exit sensor are more than the required notes				2A*	Timing wheel	When the delivery belts of the GBM does not operate.				2C	Bad roller profile	In case of that a noise occurs at the double detect sensor				2D*	Reject error	When the GBM has failed to reject an abnormal note				2E	Exit quantified	When the count at the exit disagrees with other sensors				2F	Note missing at double detect	When an note detected by the feed sensor isn't seen at the double detect				30	Reject rate Exceed	When reject events are more than 5, If more than 8, operation will be stopped.			
CODE(hex)	ERROR	The cause of errors, or explanation																																																																																													
20	Good operation																																																																																														
21	Feed failure	Failure to pick notes from the cassette																																																																																													
22	Mistracked note at feed	Note arrived at feed sensor while note still is at double detect																																																																																													
23	Mistracked note at double detect	Without being seen at feed sensor, note arrived at double detect																																																																																													
24	Mistracked note at exit	Without being seen at exit sensor, note arrived at other sensor																																																																																													
25*	Note too long at exit	Current note is longer than allowed note at the exit sensor																																																																																													
26*	Blocked exit	When the exit sensor is covered at start of dispense, the GBM will accept only the Purge command.																																																																																													
27	Too many notes	The notes detected by the exit sensor are more than the required notes																																																																																													
2A*	Timing wheel	When the delivery belts of the GBM does not operate.																																																																																													
2C	Bad roller profile	In case of that a noise occurs at the double detect sensor																																																																																													
2D*	Reject error	When the GBM has failed to reject an abnormal note																																																																																													
2E	Exit quantified	When the count at the exit disagrees with other sensors																																																																																													
2F	Note missing at double detect	When an note detected by the feed sensor isn't seen at the double detect																																																																																													
30	Reject rate Exceed	When reject events are more than 5, If more than 8, operation will be stopped.																																																																																													
<table border="1"> <thead> <tr> <th>CODE(hex)</th> <th>ERROR</th> <th colspan="4">The cause of errors, or explanation</th> </tr> </thead> <tbody> <tr> <td> </td> <td> </td> <td colspan="4"> </td> </tr> </tbody> </table>						CODE(hex)	ERROR	The cause of errors, or explanation																																																																																							
CODE(hex)	ERROR	The cause of errors, or explanation																																																																																													
MODEL: GBM,GBM1000		 Rev.: 3.0	Written	K.S.KIM	05-07-19	Sheet																																																																																									
TITLE: COMMUNICATION & COMMAND REFERENCE MANUAL			Checked	H.B.LEE	05-07-19	28																																																																																									
			Approved	E.J.LEE	05-07-19	29																																																																																									



Revision	Date	Written by	Description
31*		Jam at exit	When a note has been seen at the exit sensor during reverse running and can't be come out again.
32		Interference Recovery	When the operation of the microprocessor is interrupted but successful recovery is attained
33		Suspect exit accountancy	The GBM may not guarantee the exit count. Therefore the exit sensor should be checked at need. In this case, check with the Test Dispense command.
34		RAM error	The GBM has identified whether its 'Random Access memory' is an error status or not. No operation is permitted.
35		EPROM error	The GBM has identified whether its program memory is an error status or not. No operation is permitted.
36		Operation timeout	When the current interface time is exceeded
37		RAM corruption	When The internal counters are corrupted.
40		Cassette Motor Echo Error	In case of cassette home position error
41*		Mistracked note at S17 sensor	In case of the note arrived at S17 sensor without being seen by S15 sensor
42*		Mistracked note at S23 sensor	In case of the note arrived at S23 sensor without being seen by S17 sensor
43*		Reject gate open error	If the reject gate has been opened.
4D		Corrupted note count	If the requiring note count is corrupted.

* This error codes summary is based on SDD emulation (Excepting for 40 hex ~ 4D hex), so that an error may happen unexpectedly. In that case, contact us please.

NOTE

In dispensing a new note, the noise of a cassette occurring once in a while is not abnormal.

MODEL: GBM,GBM1000		Written	K.S.KIM	05-07-19	Sheet
TITLE: COMMUNICATION & COMMAND REFERENCE MANUAL		Checked	H.B.LEE	05-07-19	29
		Rev.: 3.0	Approved	E.J.LEE	05-07-19