



Product Specification

Model : LCDM-1000
(Cash Dispensing Unit)
Total Page : 7 pages (including cover)

Date : 2002. 3
Version : V3.0(INT)



PULOON Technology Inc.



= Contents =

1. Preview and Features

- 1-1. Preview
- 1-2. Features

2. SPECIFICATION

- 2-1. General Specification
- 2-2. Electrical Features
- 2-3. Operation Environment

3. LAYOUT

4. CONNECTOR SPEC.

- 4-1. Power Connector
- 4-2. Communication Connector
- 4-3. Serial Communication Specification
- 4-4. Dip Switch Assignment



1. Preview and Features

1.1 Preview

LCDM-1000 is the cash-dispensing unit that can be applied to ATM and notes exchanger for retail market. The main function is to dispense the exact number of banknotes in the cassette by a customer's request and to transfer to the customer automatically.

1.2 Features

- 1) To separate notes by friction rollers
- 2) To prevent double dispensing case by mechanical double detect mechanism
- 3) To implement mold guides and paths to minimize jam occurrence
- 4) To maximize convenience in maintenance or clearing by opening guide structure
- 5) To realize so compact and slim size to be easily applied in even small space
- 6) To speed at a rate of 3 notes/sec
- 7) After power failure, bills on the path are rejected to reject tray when power turns on again (Auto reject function)



2. SPECIFICATION

2.1 General Specification

2.1.1 Denomination	1 Denomination
2.1.2 Cassette Capacity	approx 1,000 notes (123 mm)
2.1.3 Dispensing Speed	3 notes/sec
2.1.4 Usable Note Size	Width: 100 ~ 162mm Height: 62 ~ 78mm
2.1.5 Double Feeding Detection	Mechanical type
2.1.6 Reject Capacity	About 30 notes
2.1.7 Access Type	Front Access Type
2.1.8 Dimension (unit:mm)	310.2(D) x 225(H) x 270.5(W)
2.1.9 Near-end detection	About 30~50 notes
2.1.10 Bill-end detection	0 or Approx. 10~30 notes (by setting dip switch, refer to Chapter4.4)
2.1.11 Interface	RS 232C

2.2 Electrical Features

2.2.1 Rated Voltage	DC24V±10%
2.2.2 Rated Consuming Current	
- Standby Status	160 mA
- Average Current	900 mA

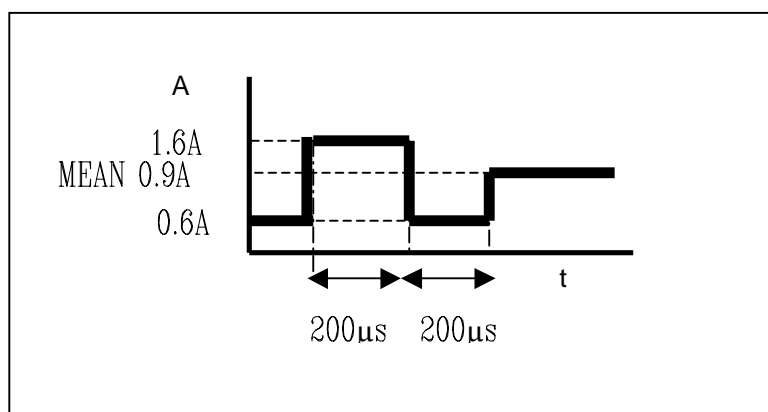



2.3 Operation Environment

2.3.1 Operation Temperature

+ 5. ~ +40.

2.3.2 Storage Temperature

-10. ~ +60.

2.3.3 Operation Humidity

20% ~ 80% RH

2.3.4 Storage Humidity

10% ~ 90% RH

3. LAYOUT

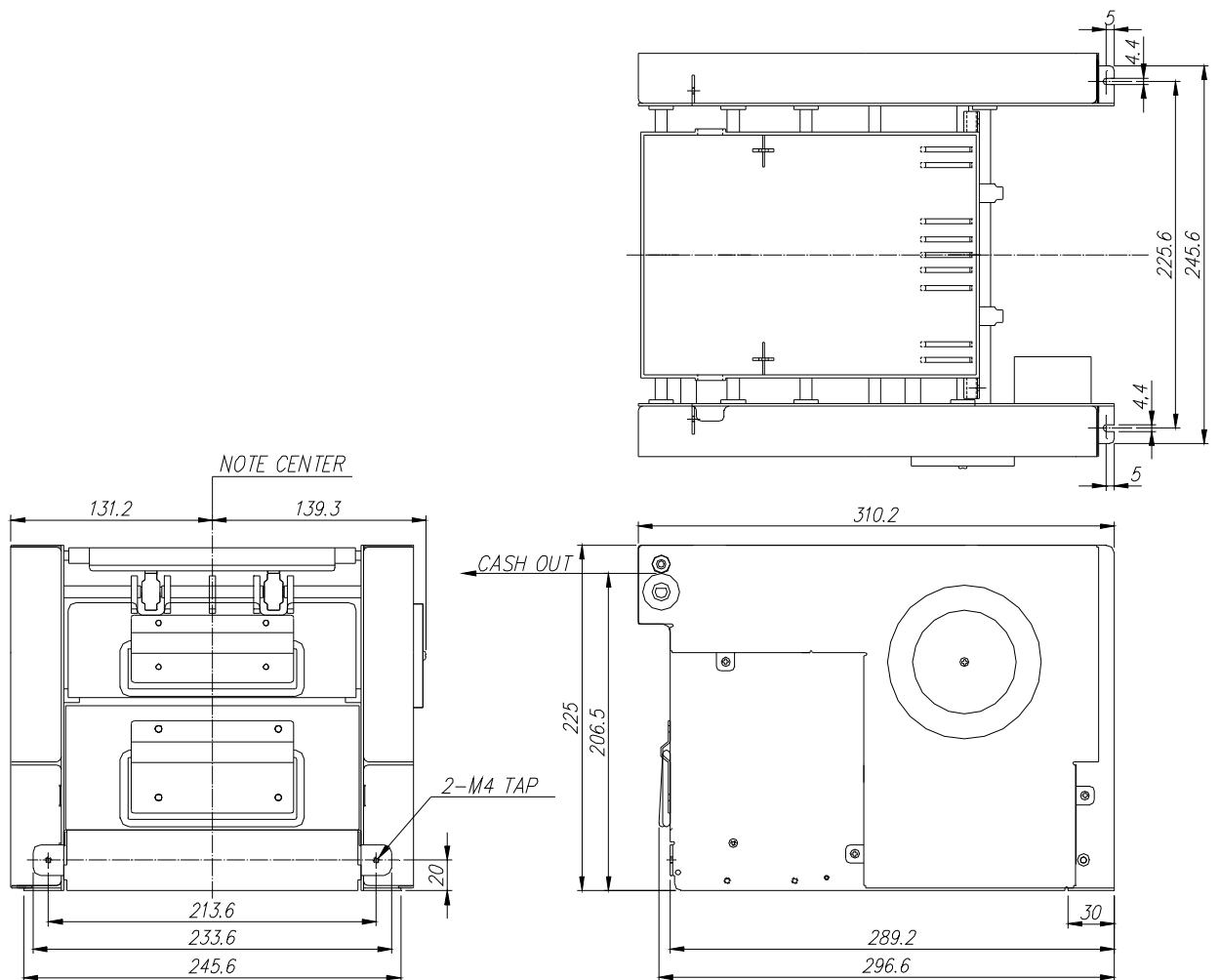



4. CONNECTOR SPEC.

4.1 Power Connector

The power connector is positioned at the bottom of the LCDM MAIN Controller PCB.

Connector on Controller : MOLEX 5566VW0

Matching Connector : MOLEX 5557D-02

The switch should be set as "ON" state like figure.

Pin No	Function
1	+24V
2	GND

4.2 Communication Connector

The communication connector is positioned at the bottom of the LCDM MAIN Controller PCB. It is 9-way and D-type connector.

Pin No	Name	Function
1		Not used
2	RXD	Received data
3	TXD	Transmitted data
4		Not used
5	GND	System ground
6		Not used
7		Not used
8		Not used
9		Not used
10		Not used

4.3 Serial Communication Specification

Baud rate	9600 bps
Data bits	8 bits
Parity	No parity
Stop bits	1 stop bit

4.4 Dip Switch Assignment

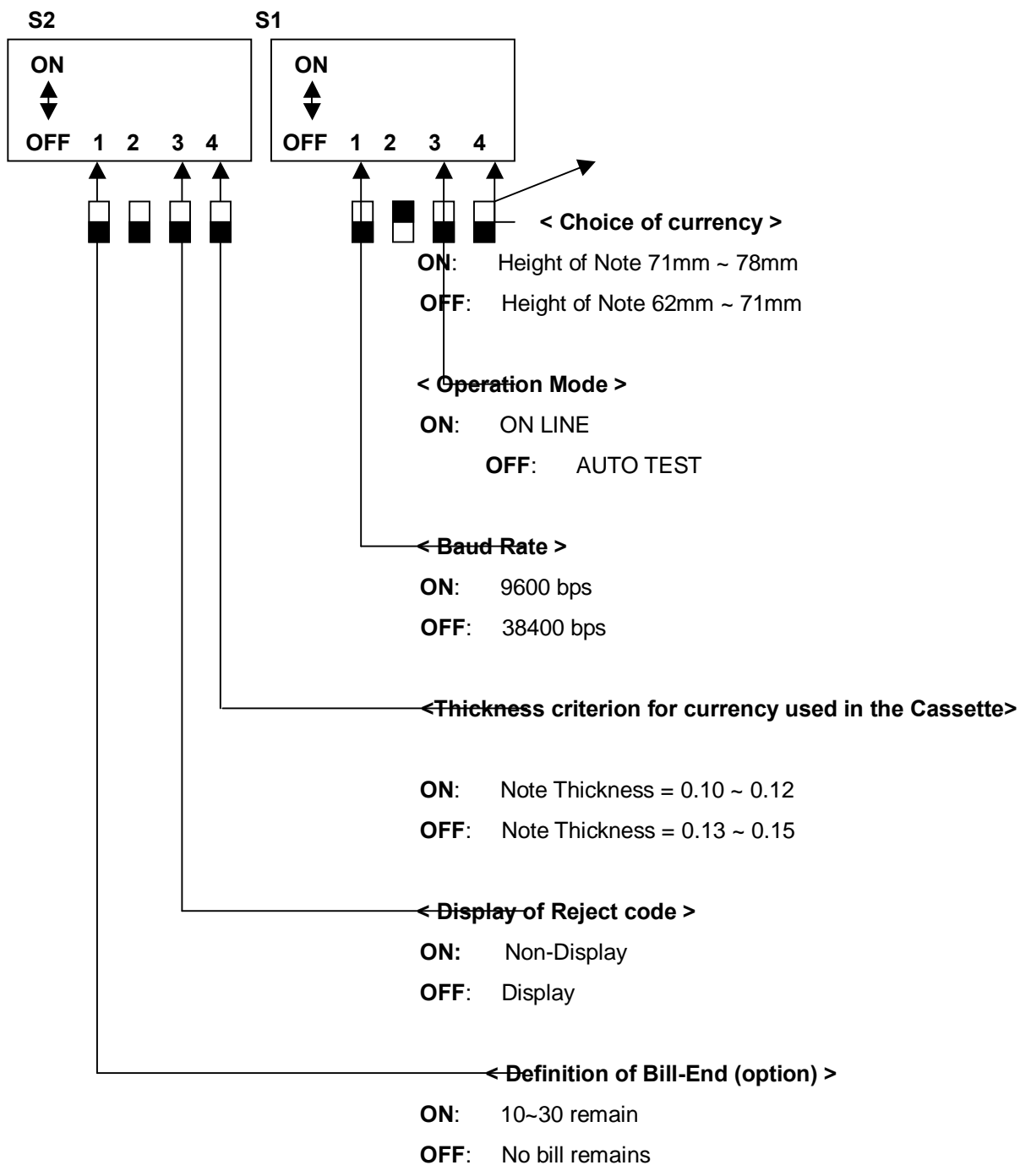

CAUTION !

Please turn on power again after changing the Dip Switch